

FULL-CHAIN SMALL SCALE LNG PRODUCT LINE

..... LNG ISO CONTAINER

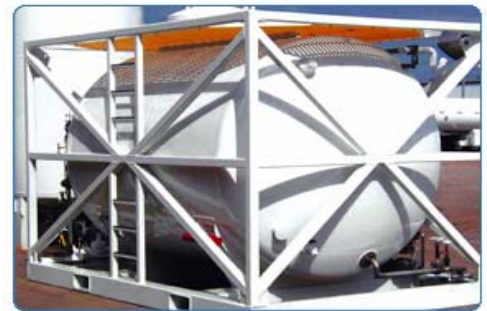

Volume		Design Pressure		Design Temperature		Certificates/Codes
m ³	gallons	kPa.G	psig	C	F	
20'	20	800	116	-165	-265	ABS, DNV, GL, LR, CCS, DOT
40'	40					

EnerTech USA, Inc.

Full-Chain Small Scale LNG Solutions

FULL-CHAIN SMALL SCALE LNG PRODUCT LINE

..... LNG TANK TRAILER

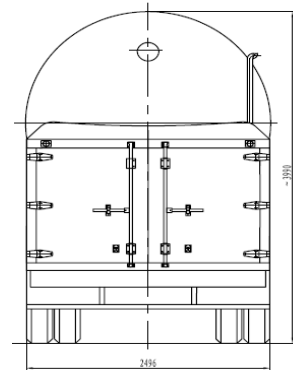
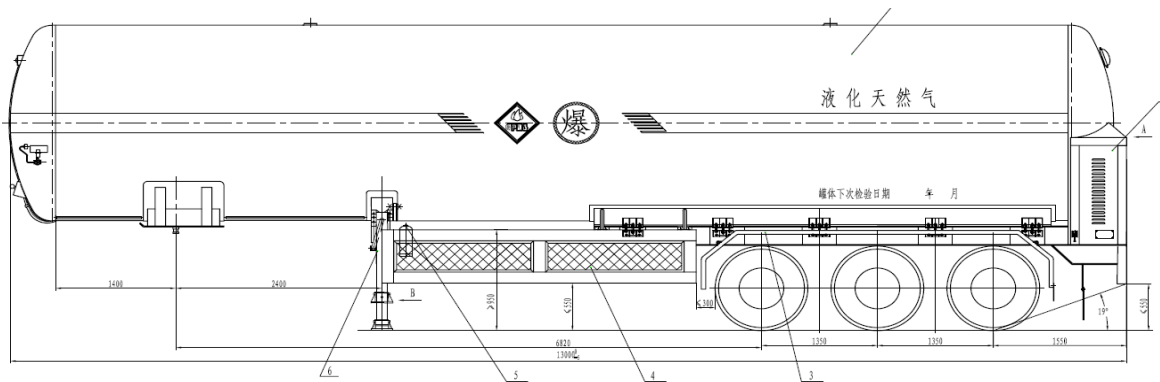

Volume		Design Pressure		Design Temperature		Certificates/Codes
m ³	gallons	kPa.G	psig	C	F	
40	10,567	800	116	-165	-265	ASME, DOT
50	13,209					

EnerTech USA, Inc.

Full-Chain Small Scale LNG Solutions