

**FULL-CHAIN SMALL SCALE LNG PRODUCT LINE**

..... LNG TANK TRAILER

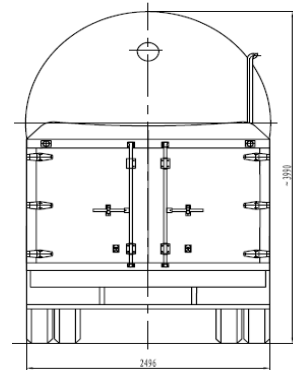
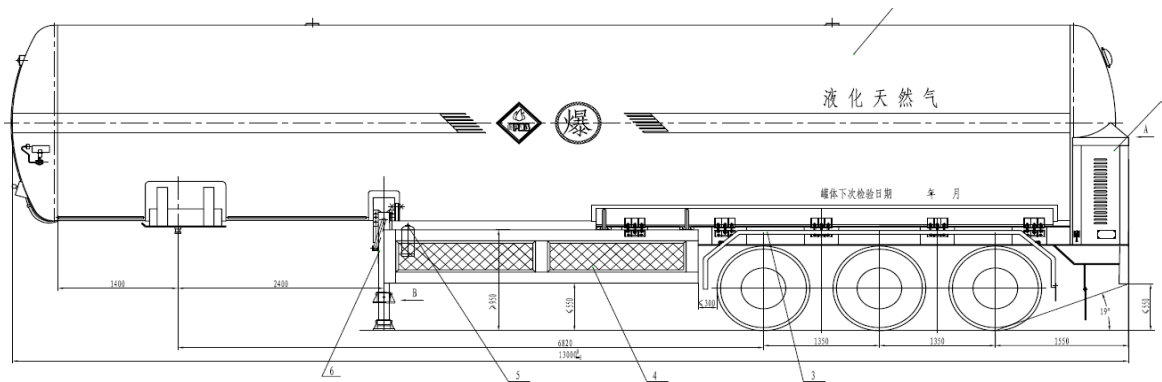

Volume		Design Pressure		Design Temperature		Certificates/Codes
m <sup>3</sup>	gallons	kPa.G	psig	C	F	
40	10,567	800	116	-165	-265	ASME, DOT
50	13,209					

**EnerTech USA, Inc.**  
Full-Chain Small Scale LNG Solutions